

产品尺寸图 (DIMENSION)

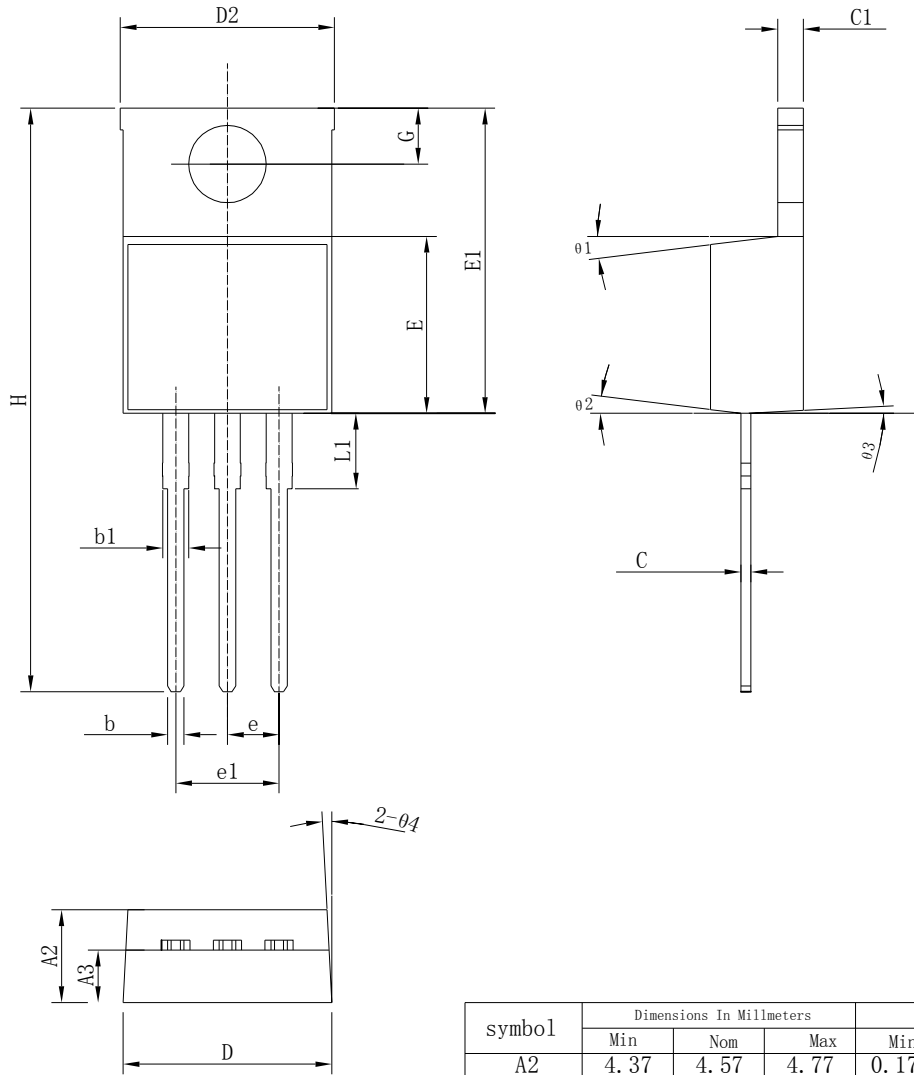

symbol	Dimensions In Millimeters			Dimensions In Inches		
	Min	Nom	Max	Min	Nom	Max
A2	4.37	4.57	4.77	0.172	0.180	0.188
A3	2.45	2.60	2.75	0.096	0.102	0.108
b	0.75	0.81	0.95	0.029	0.032	0.037
b1	1.15	1.27	1.52	0.045	0.050	0.060
C	0.43	0.50	0.62	0.017	0.020	0.024
C1	1.15	1.27	1.39	0.045	0.050	0.055
D	9.66	10.16	10.28	0.380	0.400	0.405
D2	10.0	10.26	10.5	0.394	0.404	0.413
E	8.38	8.70	8.90	0.330	0.343	0.350
e	2.42	2.54	2.66	0.095	0.100	0.105
E1	14.48	15.00	15.87	0.570	0.590	0.625
e1	4.83	5.08	5.33	0.190	0.200	0.210
G	2.54	2.74	3.04	0.100	0.108	0.120
H	28.4	28.68	28.9	1.118	1.129	1.138
θ 1	—	7°	—	—	7°	—
θ 2	—	7°	—	—	7°	—
θ 3	—	3°	—	—	3°	—
θ 4	—	3°	—	—	3°	—
L1	3.5	3.714	3.9	0.089	0.094	0.099

FSMC

图名 NAME	TO-220HJ		图号 DWG. NO.	DD0083	SH 1 OF 1
材质 MATERIAL	Cu		REV.	A	
单位 UNITS	mm[INCH]	核准 APPROVE	审核 CHECKED	制图 DRAWN	 第三角法
日期 DATE	2020.10.09				
比例 SCALE	N. T. S.				